



# VERDEGRO®

**A LEADER...  
NOT A FOLLOWER!**

MANUFACTURER OF TRAFFIC SAFETY  
SYSTEMS & LED LIGHTING TOWERS

# CONTENT

## LIGHTING

INTRO	6
OVERVIEW	8
HYBRID LED LIGHT TOWER	10
HYBRID LED LIGHT TOWER CUBE	12
LED LIGHT TOWER TRAILER	14
LED LIGHT TOWER UNIT	16



HYBRID LED LIGHT TOWER (LLTT-H)    HYBRID LED LIGHT TOWER CUBE (LLTC-H)    LED LIGHT TOWER TRAILER (LLTT)    LED LIGHT TOWER UNIT (LLTU)

## CRASH

INTRO	18
OVERVIEW	20
TRAILER TRUCK MOUNTED ATTENUATOR	22
TRUCK MOUNTED ATTENUATOR	24
LIGHT TRUCK MOUNTED ATTENUATOR	26
TRUCK MOUNTED ATTENUATOR-EU	28
ARROW BOARD FOR TMA	30



TRAILER TRUCK MOUNTED ATTENUATOR (TTMA)    TRUCK MOUNTED ATTENUATOR (TMA-US)    LIGHT TRUCK MOUNTED ATTENUATOR (LTMA)    TRUCK MOUNTED ATTENUATOR-EU (TMA-EU)    OPTIONAL ARROW BOARDS FOR TMA'S

## TRAFFIC

INTRO	32
OVERVIEW	34
SOLAR MESSAGE TRAILER	36
SOLAR MESSAGE UNIT	38
ROOF MOUNTED DISPLAY	40
ARROW TRAILERS	42
MOBILE VARIABLE MESSAGE SIGNS	44
MOBILE LANE SIGNALING	46
MOBILE AUTOMATIC ROADBLOCK SYSTEM	50



SOLAR MESSAGE TRAILER (SMT)    SOLAR MESSAGE UNIT (SMU)    ROOF MOUNTED DISPLAY (RMD)    ARROW TRAILERS (AT)    MOBILE VARIABLE MESSAGE SIGNS (VMS)



MOBILE LANE SIGNALING (MLS)



MOBILE AUTOMATIC ROADBLOCK SYSTEM (M.A.R.S.)



SALES@VERDEGRO.COM  
0031 765017990

OR SEARCH FOR YOUR LOCAL  
DISTRIBUTORS AT OUR WEBSITE  
[WWW.VERDEGRO.COM/DISTRIBUTORS](http://WWW.VERDEGRO.COM/DISTRIBUTORS)

# WORLD WIDE MARKET



VERDEGRO  
IS A PROUD  
MEMBER OF



UNIQUE HYBRID-  
AND SOLAR POWERED  
LIGHTING SERIES

# LIGHTING SOLAR AND HYBRID POWERED LIGHT TOWERS, SAVE BIG MONEY ON REFUELING AND MAINTENANCE!

A NEW CONCEPT FOR THE WORLD WIDE MARKET...

☀️🔋 HYBRID POWERED

☀️ SOLAR POWERED



HYBRID LED LIGHT TOWER (LLTT-H)



HYBRID LED LIGHT TOWER CUBE (LLTC-H)



LED LIGHT TOWER TRAILER (LLTT)



LED LIGHT TOWER UNIT (LLTU)



HIGHEST LIGHTING  
HOURS WITHOUT  
REFUELING



- SOLAR POWER SYSTEM (350 W)
- HIGH-EFFICIENCY LED LIGHTS (BRAND: VISION X)  
— ALSO EXPLOSION PROOF LIGHTS AVAILABLE
- PHOTOCELL DAYLIGHT SENSOR (AUTOMATIC ON/OFF)
- SPRING- DRIVEN CABLE DRUM
- 7 SECTION VERTICAL TOWER (STEEL GALVANISED)
- FORKLIFT SPROCKETS ON TOP +  
— BELOW CHASSIS
- INFORMATION LED BACKLIGHT  
— CONTROLLER SCREEN
- SOLAR POWER SYSTEM (350 W)
- HIGH-QUALITY KUBOTA 2-CYLINDER  
— DIESEL ENGINE WATER- COOLED
- FUEL TANK CAPACITY 140 L
- INTEGRAL SPILL  
— CONTAINMENT
- TWO FRONT +  
— TWO BACK OUTRIGGERS  
— AND LEVELING JACKS
- TORSION RUBBER  
— SUSPENSION AXLE

FUEL CONSUMPTION 1,46 L EACH DAY/  
60 NIGHTS BEFORE REFUELING!  
\* ASK FOR FULL SPECIFICATIONS





VARIABLE NUMBER  
OF LED LIGHTS, SOLAR  
PANELS AND BATTERIES

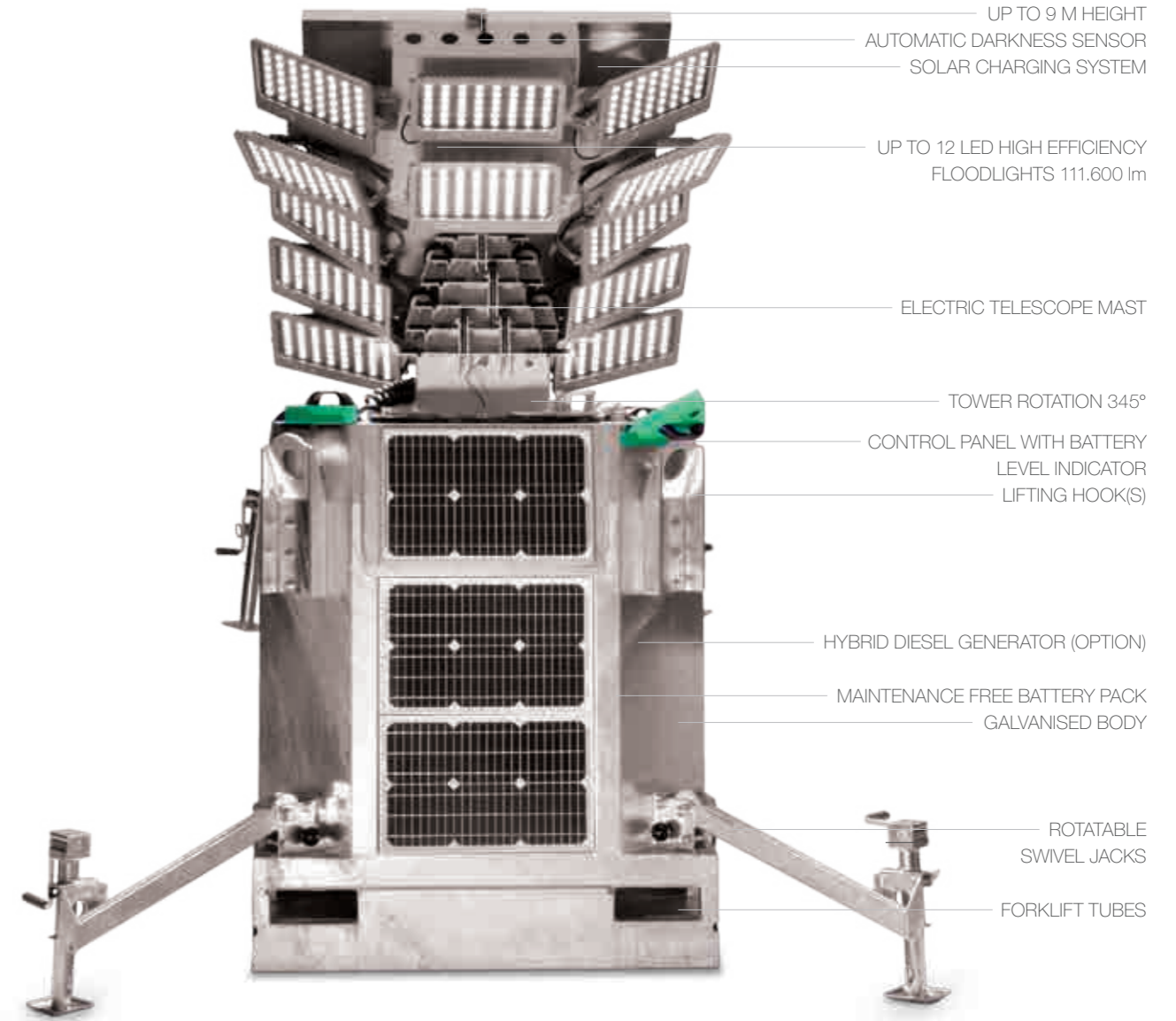

1250 KG

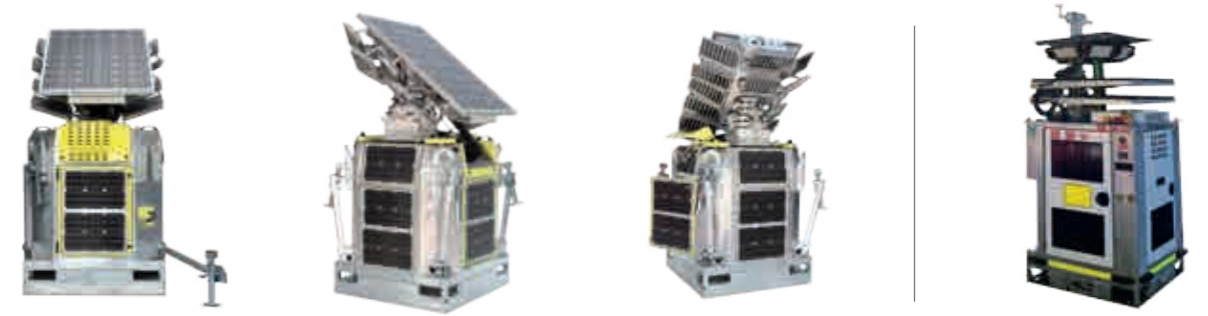



SOLAR POWERED CO<sub>2</sub>  
NEUTRAL AND NOISELESS  
MOBILE LIGHTING TRAILER

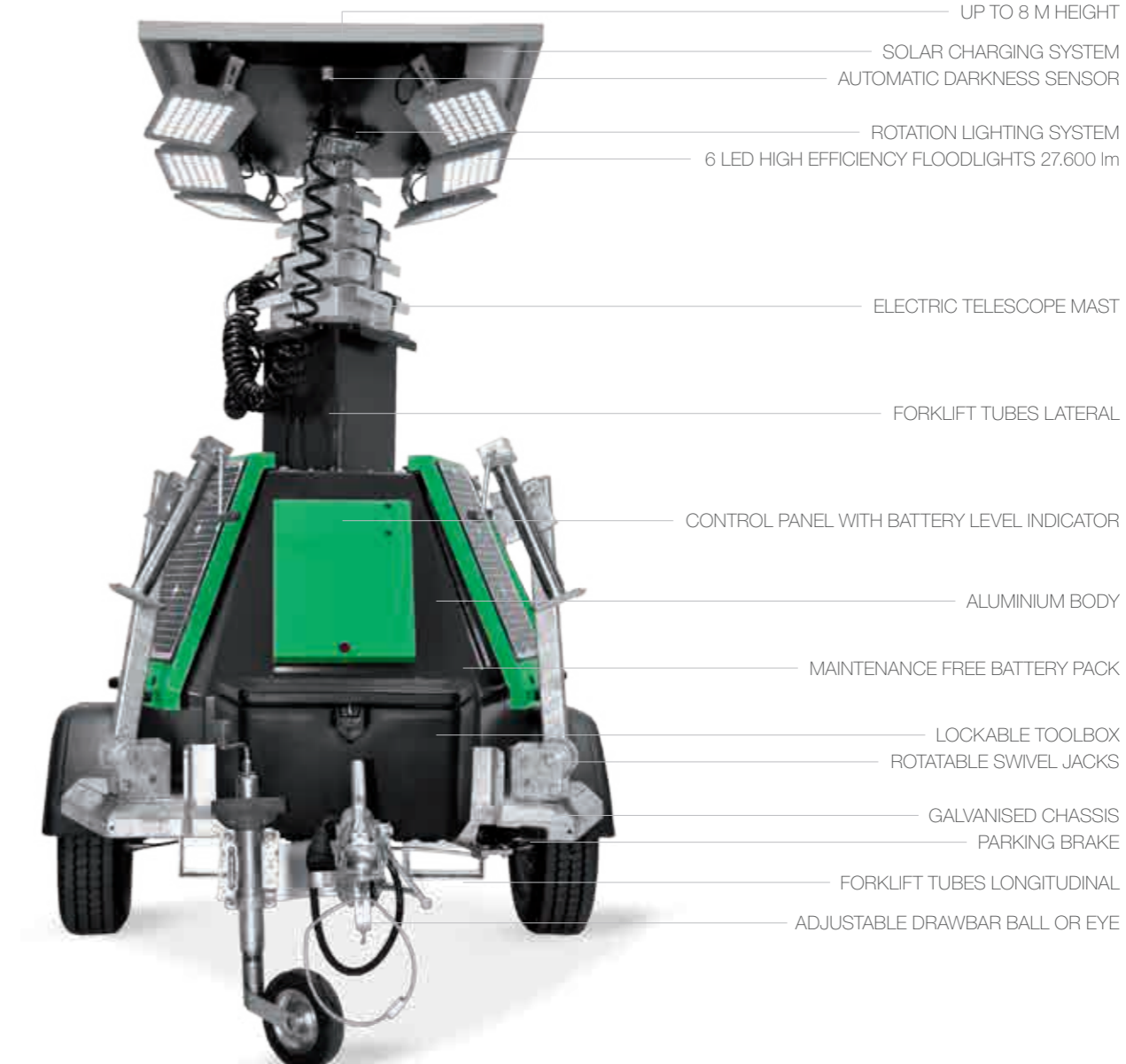

UP TO 8 M HEIGHT

SOLAR CHARGING SYSTEM  
AUTOMATIC DARKNESS SENSOR

ROTATION LIGHTING SYSTEM  
6 LED HIGH EFFICIENCY FLOODLIGHTS 27.600 lm

ELECTRIC TELESCOPE MAST

FORKLIFT TUBES LATERAL

CONTROL PANEL WITH BATTERY LEVEL INDICATOR

ALUMINIUM BODY

MAINTENANCE FREE BATTERY PACK

LOCKABLE TOOLBOX  
ROTATABLE SWIVEL JACKS

GALVANISED CHASSIS  
PARKING BRAKE

FORKLIFT TUBES LONGITUDINAL  
ADJUSTABLE DRAWBAR BALL OR EYE

745 KG







THIS LIGHTING UNIT  
HAS BEEN FULL-SCALE  
CRASH TESTED

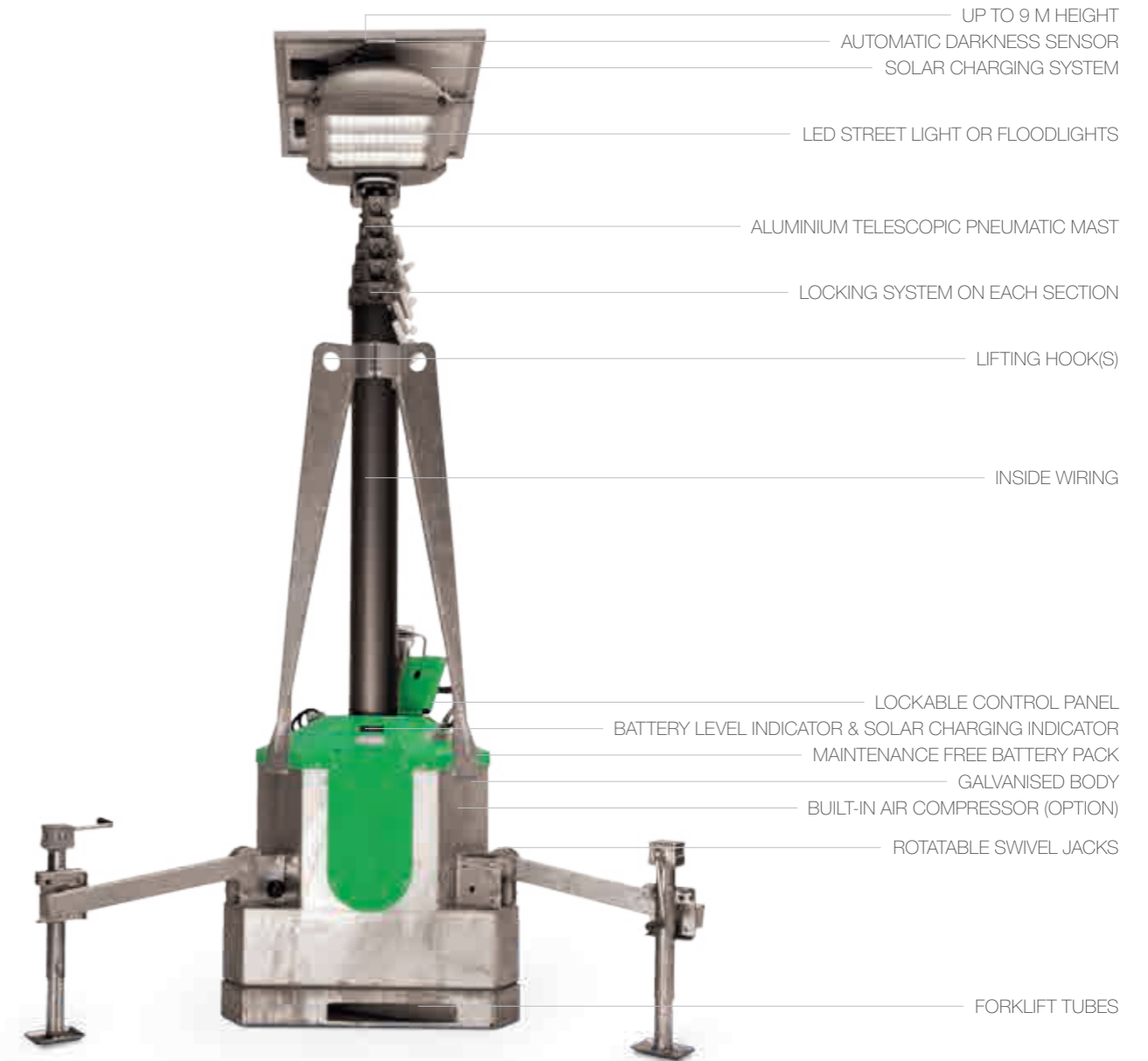

450 KG





ALL UNIQUE &  
FULL SCALE CRASH  
TESTED SYSTEMS

ARROW  
BOARDS  
FOR TMA'S  
SEE P30!

# CRASH TRAFFIC AND WORKZONE SAFETY ALUMINUM AND GALVANISED STEEL PARTS ONLY

A NEW CONCEPT FOR  
THE WORLD WIDE MARKET...





ARROW  
BOARDS  
FOR TMA'S  
SEE P30!

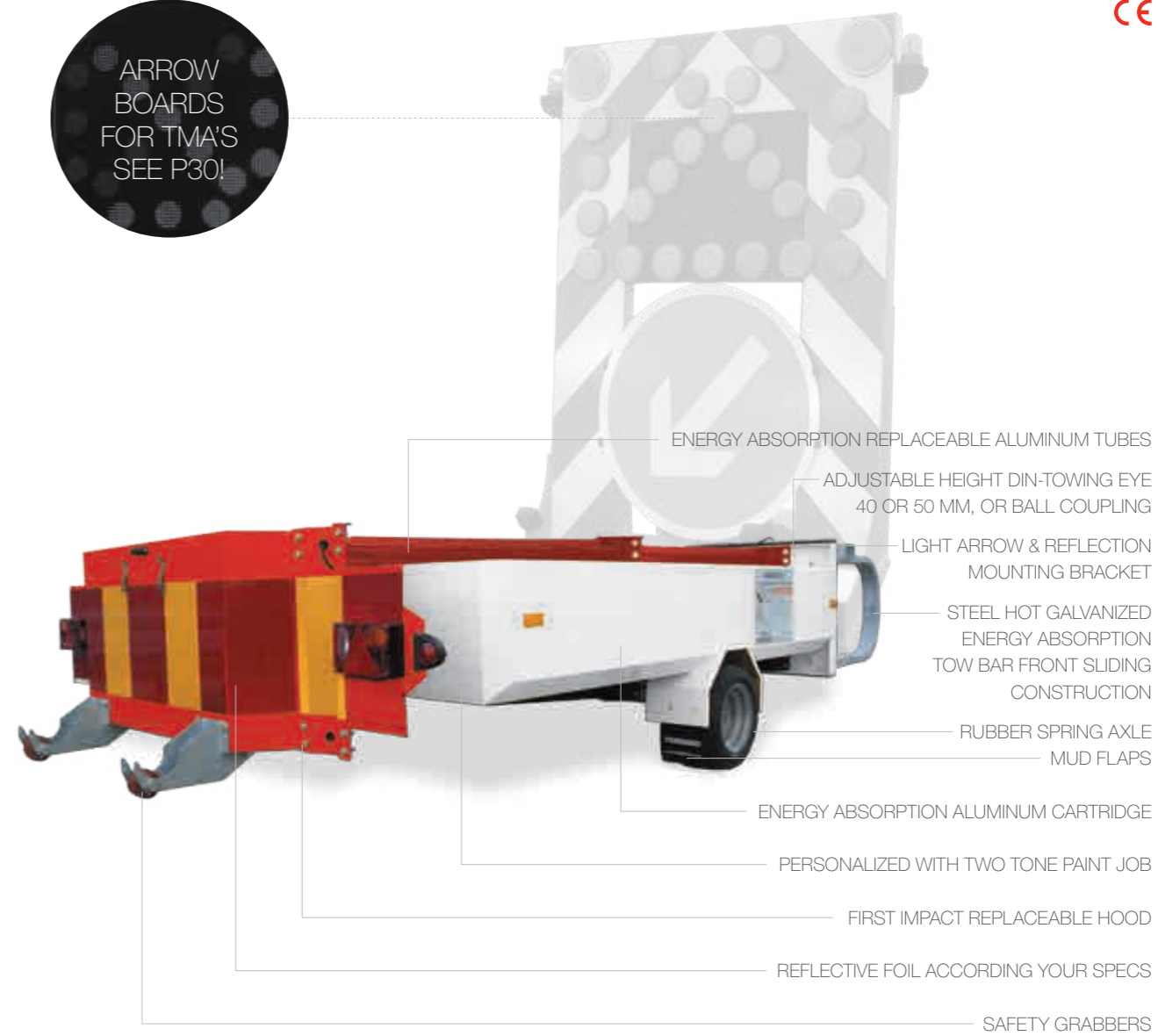

NCHRP 350/100 kph TESTED INCLUDING  
OPTIONAL IMPACT TESTS  
OPTIONAL ARROW BOARD

**740 KG**

EASY TO OWN  
AND OPERATE  
FAST & QUICK





A UNIQUE DESIGN  
PROVEN QUALITY

ARROW  
BOARDS  
FOR TMA'S  
SEE P30!

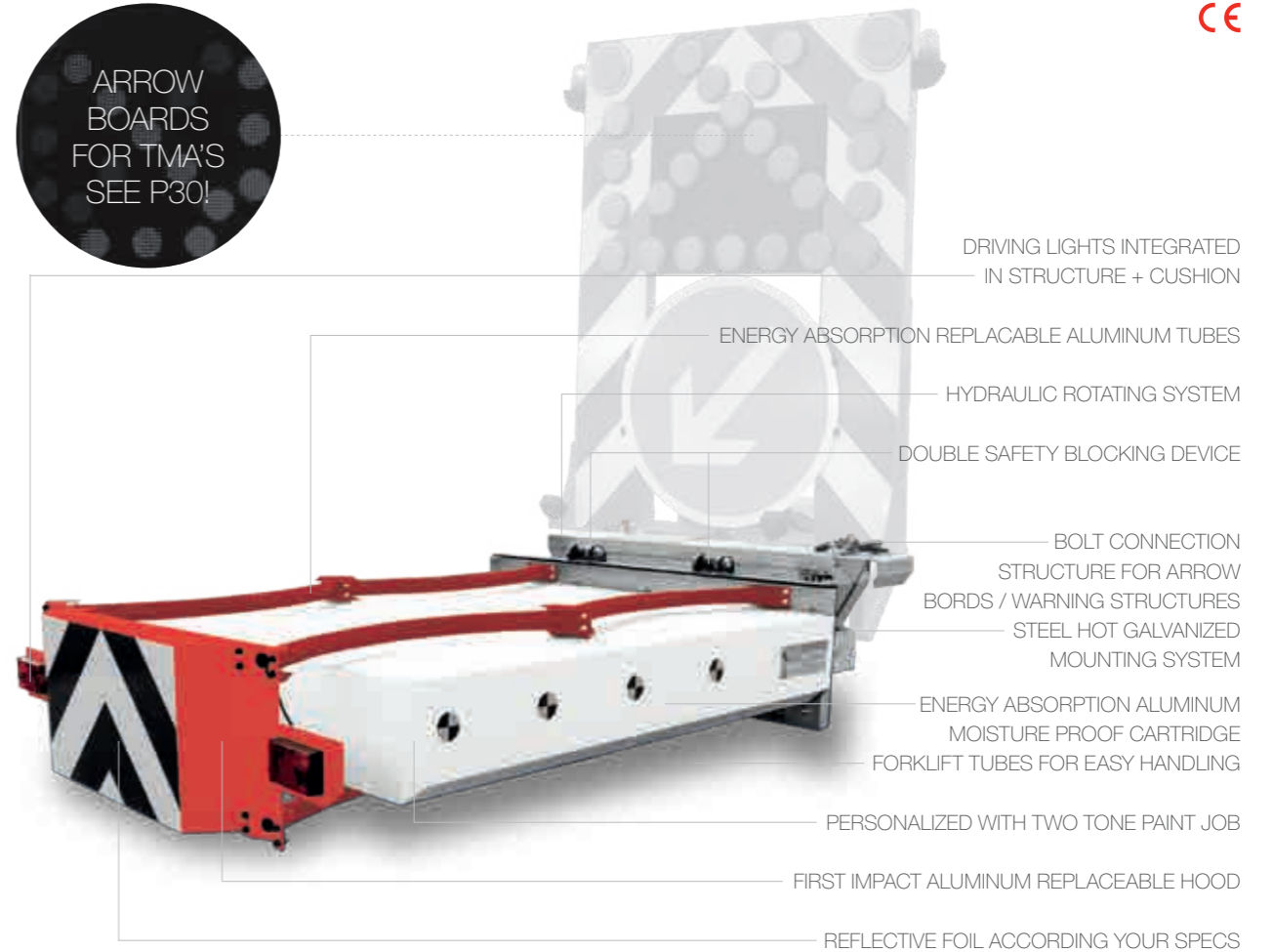

TESTED ACCORDING THE NCHRP 350  
TLIII 100 kph (3-50 / 3-51 / 3-52 / 3-53).  
2000P TESTS WERE DONE WITH A  
2000 KG US PICK-UP TRUCK  
TESTED ACCORDING THE UK OPTIONAL 110 KPH TEST (TD 49/07)  
OPTIONAL 110 kph TEST

950 KG





FOR LIGHT  
VEHICLES TESTED  
AND APPROVED

ARROW  
BOARDS  
FOR TMA'S  
SEE P30!



CE  
PATENTED NO 2011417 (LTMA)

- PERSONALIZED WITH TWO TONE PAINT JOB
- 2.5 TON VAN UP TO 9 TON TRUCK
- HYDRAULIC ROTATING SYSTEM INCLUDED
- OPTIONAL SUBFRAME FOR MOUNTING BETWEEN CHASSIS AND CARGOFLOOR ON REQUEST
- ENERGY ABSORPTION ALUMINUM MOISTURE PROOF CARTRIDGE
- ENERGY ABSORPTION REPLACABLE ALUMINUM TUBES
- FIRST IMPACT ALUMINUM REPLACEABLE HOOD
- REFLECTIVE FOIL ACCORDING YOUR SPECS

TESTED ACCORDING THE  
NCHRP-350 TLII 70 kph (2-50 / 2-51).  
2000P TESTS DONE WITH  
2000 KG US PICK-UP TRUCK

**280 KG**





EUROPEAN STANDARDS,  
PROVEN QUALITY

ARROW  
BOARDS  
FOR TMA'S  
SEE P30!



NO PAPER  
INSIDE,  
**ONLY HIGH  
QUALITY  
ALUMINUM**

TESTED IN THE EU SPIRIT OF THE NCHRP 350 TL3 100 KPH  
(3-50/3-51/3-52/3-53) 2000P TEST'S WERE DONE WITH 2000KG  
MORE EUROPEAN STYLE SUV'S

**750 KG**





ARROW BOARDS  
TO FIT YOUR  
SPECIFIC NEEDS

# OPTIONAL ARROW BOARD?

CONTACT US AND MAKE  
YOUR TMA COMPLETE...







A WIDE RANGE  
OF HIGH QUALITY  
TRAFFIC SYSTEMS

# TRAFFIC THE INTERNATIONAL VMS STANDARDS STARTS HERE

A NEW CONCEPT FOR  
THE WORLD WIDE MARKET...





# FULL COLOR SOLAR POWERED MESSAGE TRAILER



- 880 WP SOLAR SYSTEM
- SIGN PROGRAMMABLE BY TABLET OR SMARTPHONE
- LOW POWER CONSUMPTION FULL COLOR LED SIGN
- UNIQUE AUTOMATIC ROTATION & STABILIZATION SYSTEM
- ONE BUTTON OPERATION
- EASY-TO-USE FRONT MOUNTED CONTROL PANEL
- SPARE TIRE AND CONE STORAGE SPACE
- REMOVABLE GALVANISED DRAWBAR
- RUBBER SUSPENSION BRAKED AXLE
- 2 ALUMINUM PAINTED BATTERY COMPARTMENTS
- 4 LIFT EYES ON EACH CORNER
- GALVANISED CHASSIS
- PORTABLE RUMBLE STRIPS STORAGE
- STABILIZER CHASSIS FOR HEAVY WIND LOADS

OPTICS ACC. NEN-EN 12966  
EMC TESTED (ELECTROMAGNETIC COMPATIBILITY)  
WIFI OR UMTS WIRELESS COMMUNICATION

**750 KG (UP TO 1100 KG)**



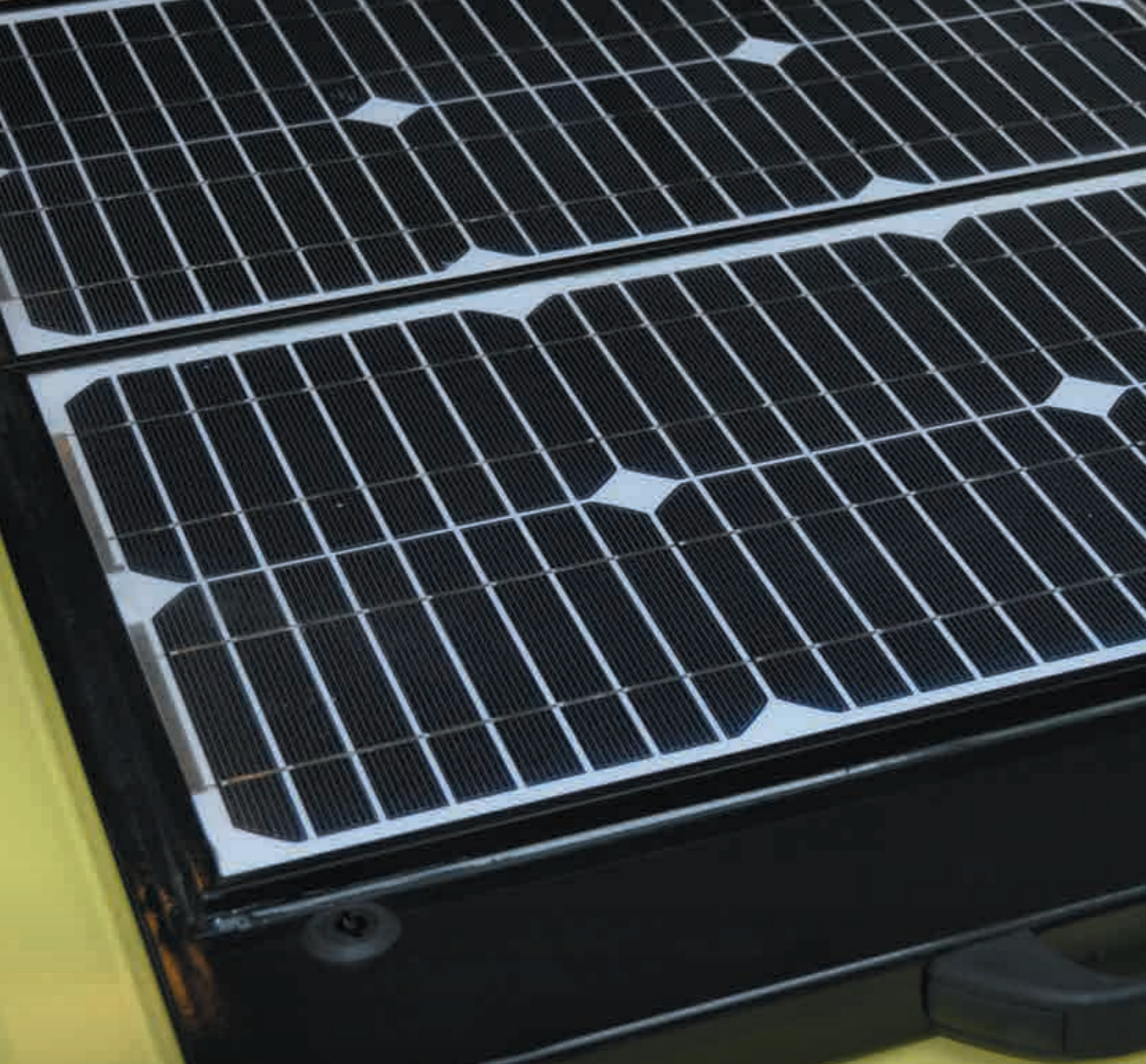

TEMPORARY STAND ALONE  
SOLAR OR HYBRID POWERED  
ROAD INFORMATION PANEL



PATENTED NO 2001420 (SMU)

SOLAR CHARGING SYSTEM  
UP TO 6,5 M HEIGHT

LOW POWER CONSUMPTION FULL COLOR LED SIGN

SIGN PROGRAMMABLE BY TABLET OR SMARTPHONE

OPTIONAL HYDRAULIC LIFT SYSTEM

MAINTENANCE FREE BATTERY PACK

OPTIONAL HYBRID POWER SYSTEM

PERSONALIZED WITH TWO TONE PAINT JOB

GALVANISED STEEL CONSTRUCTION FRAME  
FORKLIFT TUBES

OPTICS ACC. NEN-EN 12966  
EMC TESTED (ELECTROMAGNETIC COMPATIBILITY)  
WIFI OR UMTS WIRELESS COMMUNICATION

**1500 KG**

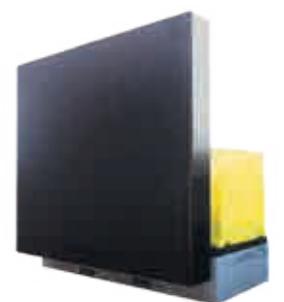



VEHICLE MOUNTED LED  
VARIABLE MESSAGE SIGNS,  
QUICK AND EASY

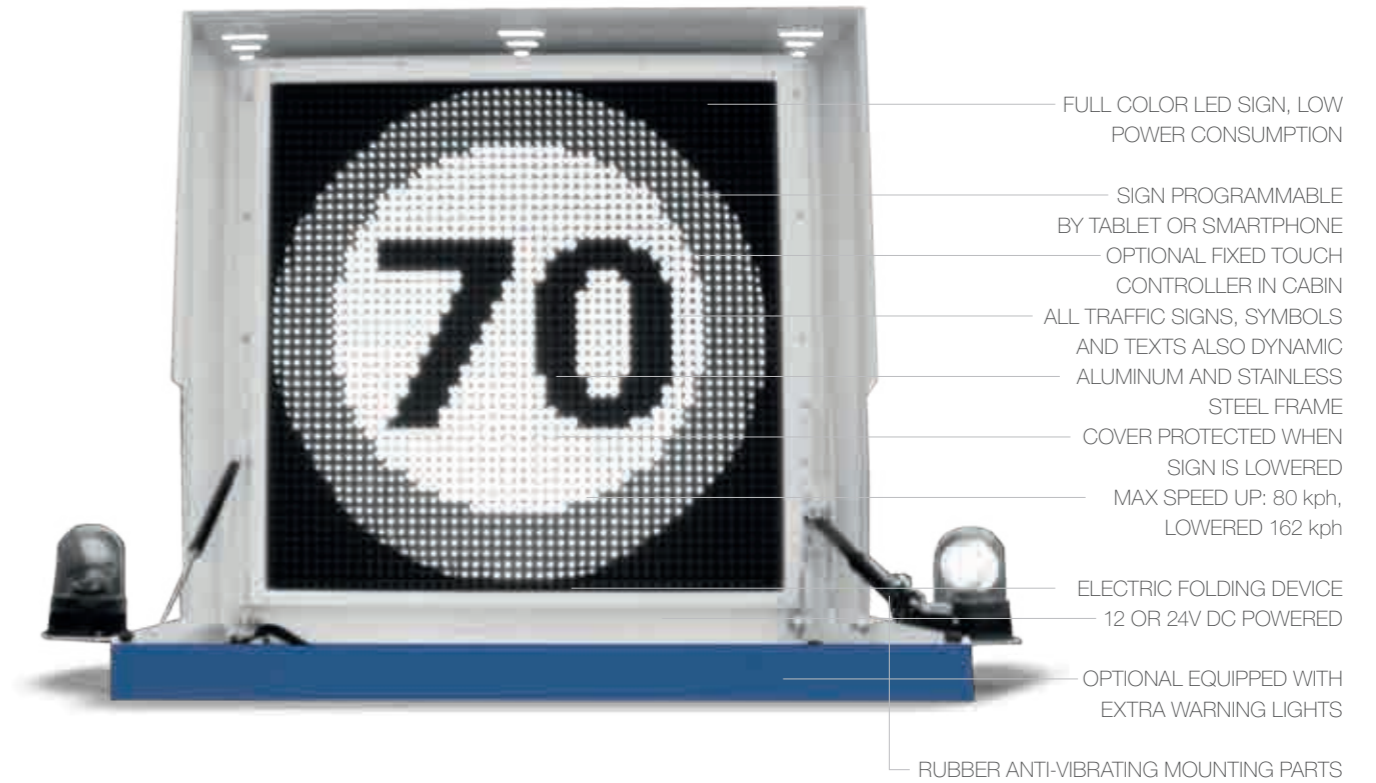

OPTICS ACC. NEN-EN 12966  
EMC TESTED (ELECTROMAGNETIC COMPATIBILITY)  
WIFI OR UMTS WIRELESS COMMUNICATION

48 KG



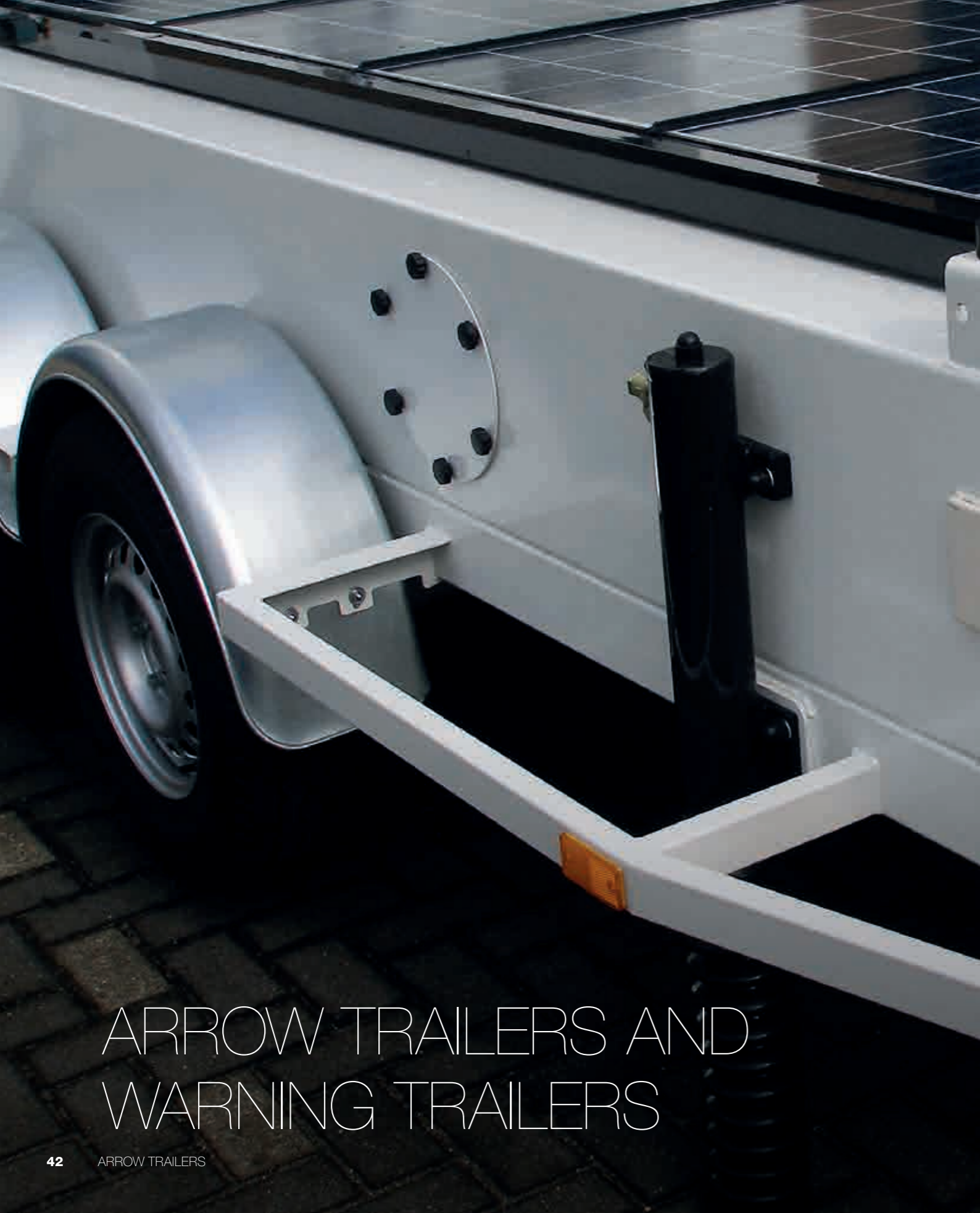

# ARROW TRAILERS AND WARNING TRAILERS



SOLAR POWERED

LED WARNING LIGHTS ACC YOUR SPECIFICATION

CLOSED OR OPEN TRAILER

REFLECTIVE FOIL ACC YOUR SPECIFICATIONS

HYDRAULIC OR MANUAL SYSTEM

SMALL OR WEIGHT CHASSIS

SINGLE OR DOUBLE AXLE

VERDEGRO MUD FLAPS

750 KG (UP TO 1400 KG)





TRAILER MOUNTED MOBILE  
VARIABLE MESSAGE SIGNS



SOLAR POWERED

SIGN PROGRAMMABLE BY TABLET OR SMARTPHONE

WIFI AND UMTS WIRELESS COMMUNICATION

FULL COLOR VMS ACC. YOUR SPECIFICATIONS

TRAILER CHASSIS OPEN OR CLOSED DESIGN

HYDRAULIC LEVELING SYSTEM, OPTIONAL VMS ROTATION

SMALL OR WEIGHT TRAILER CHASSIS

DOUBLE OR SINGLE AXLE TRAILER

OPTICS ACC. NEN-EN 12966  
EMC TESTED (ELECTROMAGNETIC COMPATIBILITY)  
WIFI OR UMTS WIRELESS COMMUNICATION

**750 KG (UP TO 1400 KG)**





MOBILE LANE SIGNALING IS AVAILABLE IN DIFFERENT CONSTRUCTIONS

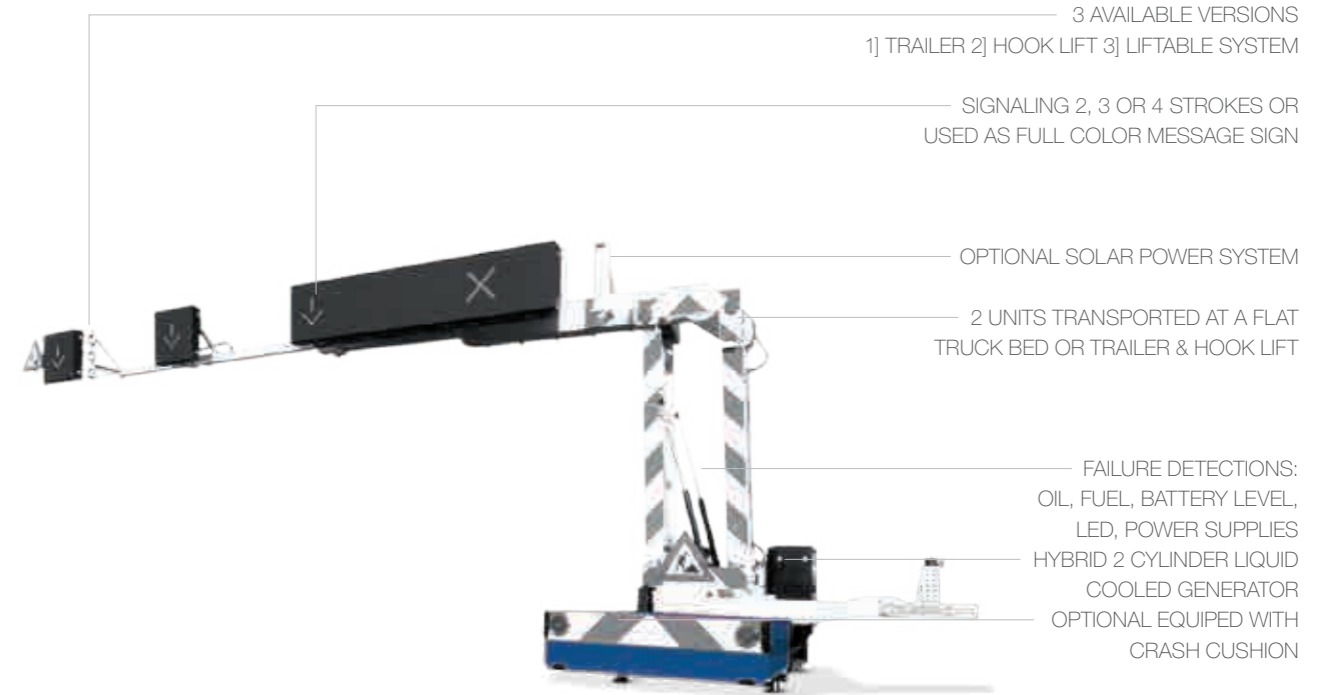

OPTICS ACC. NEN-EN 12966  
EMC TESTED (ELECTROMAGNETIC COMPATIBILITY)  
WIFI OR UMTS WIRELESS COMMUNICATION

± 10.000 KG

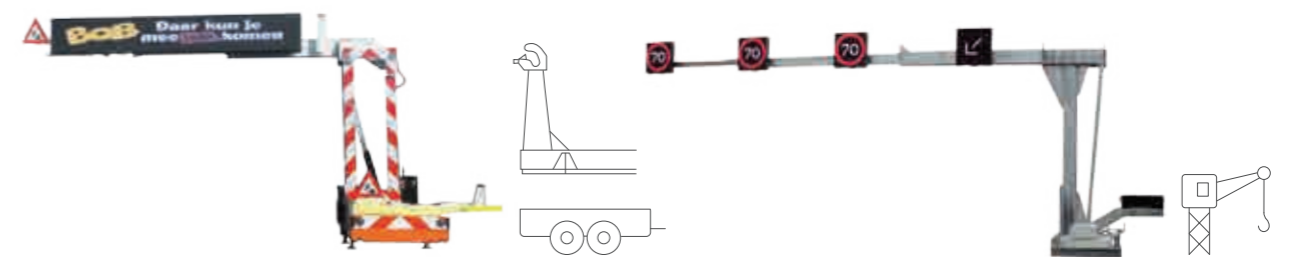





ENABLES LANE CLOSURES  
WITHOUT ACTUALLY HAVING  
PEOPLE OUT ON THE LANE



COMBINES 4 ELEMENTARY  
FUNCTIONS NECESSARY  
TO CLOSE LANES



M.A.R.S.





PATENTED NO 1031311

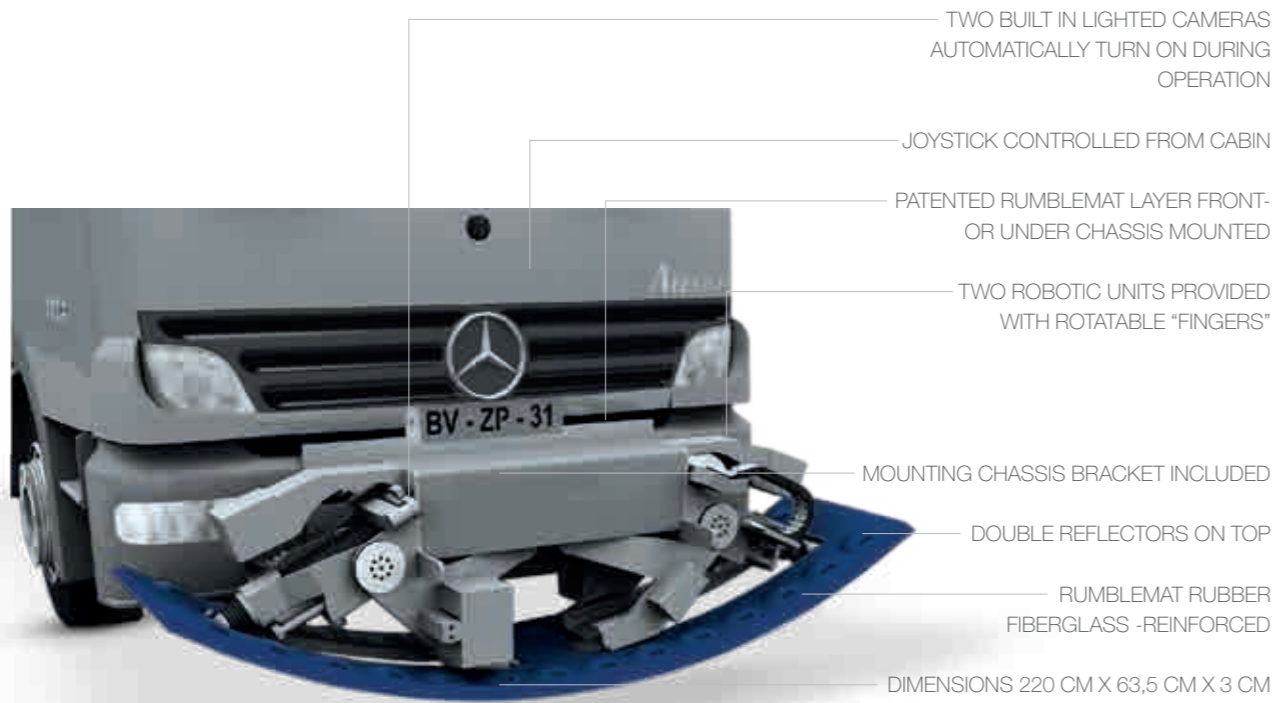

M.A.R.S.



PATENTED NO 2004413

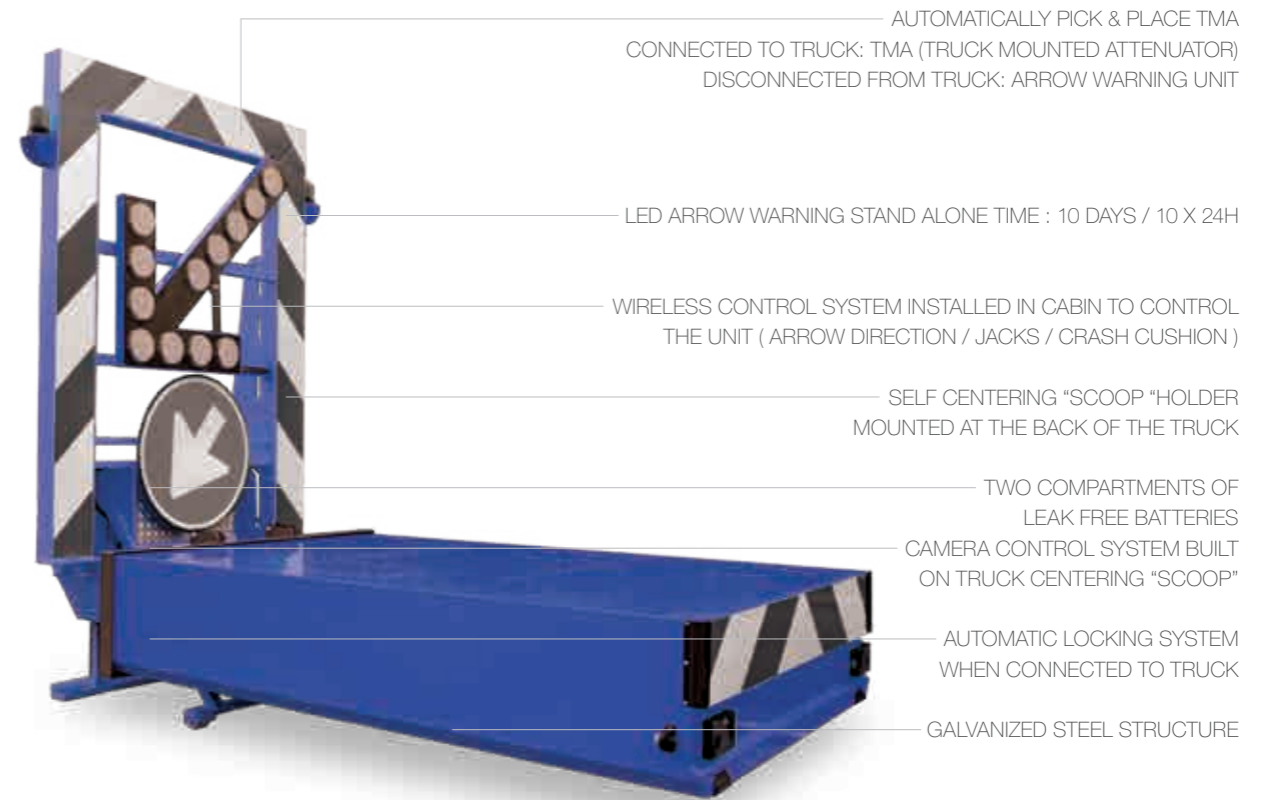

M.A.R.S.



# COLOR DOESN'T MAKE A GREAT PRODUCT GO BAD!

THAT IS WHY ALL OUR ELEMENTS ARE  
AVAILABLE IN EVERY RAL COLOR... EVEN PINK!



---

---

---

---

---

---

---

---

---

---



PROVEN SAFETY ALSO WHEN IT'S NOT A TEST



**VERDEGRO GROUP**

MUNNIKENHEIWEG 59  
4879 NE ETTEN LEUR  
THE NETHERLANDS  
EUROPE

T +31 (0) 76 - 50 17 990  
F +31 (0) 76 - 50 19 404  
INFO@VERDEGRO.COM  
WWW.VERDEGRO.COM

official dealer:

